

OBO Pro.2	SPECIFICATIONS	MODEL NO. OBO-50240
	PART NAME Piezoelectric Buzzer	SHEET 2 OF 5

MODEL NO : OBO-50240

Features : External Drive And Conformity RoHS Directive (2002/95/EC) Requests. ※1

1. General Specifications :

	Items	Spec.
1.1	Sound Pressure Level	80dB min. at 700Hz/9Vp-p Square Wave/10cm 70dB min. at 700Hz/3Vrms Sine Wave/10cm
1.2	Capacitance	60,000pF ± 30% at 120Hz
1.3	Current Consumption	4mA max. at 700Hz/9Vp-p Square Wave
1.4	Allowable Input Voltage	30Vp-p max.
1.5	Case Material	ABS (UL 94HB)
1.6	Operating Temp. Range	-20°C to +60°C
1.7	Storage Temp. Range	-30°C to +70°C
1.8	Weight	3.5 gms

2. Test Method : ※1

2.1 Standard Test Diagram

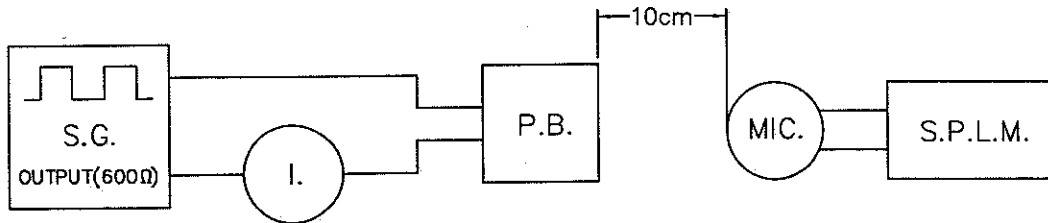

- S.G. : GAG-808G Audio Generator or Equivalent
- S.P.L.M. : Sound Pressure Level Meter IEC651 TYPE2
- I. : GDM-8145 Multimeter or Equivalent
- P.B. : Piezoelectric Buzzer

Note: please pay attention never to be applied DC voltage to piezo sounder

OBO Pro.2	SPECIFICATIONS	MODEL NO. OBO-50240
	PART NAME Piezoelectric Buzzer	SHEET 3 OF 5

2.2 Standard Test Condition ※1

Part shall be measured under a condition
(Temperature : +5 to +35°C, Humidity : 45% to 85%R.H.)
unless the standard condition.(Temperature : +25±3°C,
Humidity : 60±10%R.H.) is regulated to measure.

3. Dimensions :

Tolerance: ±0.5 mm

Unit: mm

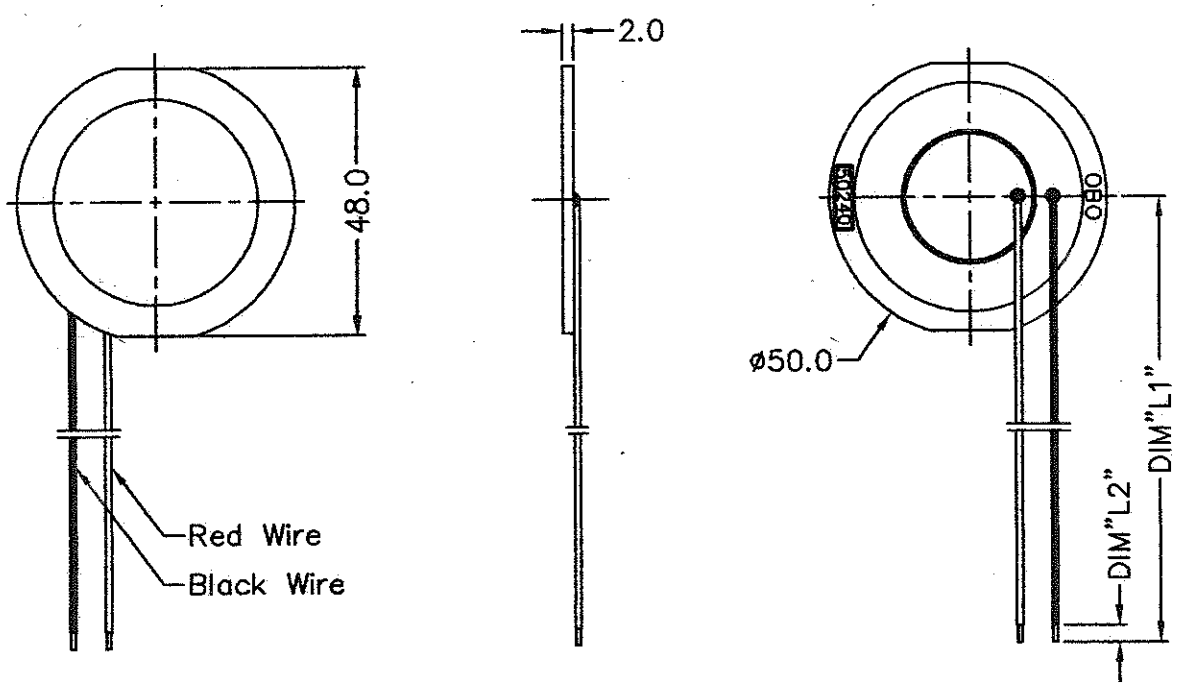

Customer	Lead Wire	DIM"L1"	DIM"L2"
Standard	UL1095#28	135±5	3±1

3.1 Environment-related substances to be controlled

◎ Piezoelectric Ceramic Disc.

RoHs Annex :

Application of lead, mercury, cadmium and hexavalent chromium,
which are exempted from the requirement of article 4(1).

* Lead in electronic ceramic parts.(e.g. piezoelectronic devices).

OBO Pro.2	SPECIFICATIONS	MODEL NO. OBO-50240
	PART NAME Piezoelectric Buzzer	SHEET 4 OF 5

4. Soldering Condition : ※1

Iron Tip Temperature	Soldering time
+ 380°C , Duration	3 seconds Max.

5. Packing Information :

